

# Cabin Management & IFE Control Cadence Switch System

## It's not your typical CMS – It's CSS!

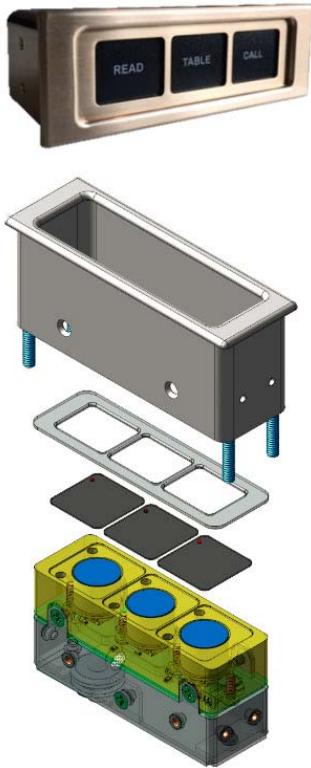

ALTO Aviation has expanded its proud mount and DECU keypad product offerings to include a new series of customizable switches. ALTO proudly introduces the Cadence Switch System, or CSS. This new series allows customizable panel dimensions and functionality through discrete logic and no software.

The foundation for this new series is the modular, discrete switch assembly. These modules come in sizes from 1-6 positions, pre-defined headphone modules and other accessory modules including USB charging, HDMI port, Bluetooth interface and ordinance signage. These modules have pre-defined harness configurations and universal overlay options. Dual LED status placement allows for vertical and horizontal orientations within the same assembly. A final configured switch panel may consist of several different modules placed together in the same bezel.

Since the overlay is defined independently of the switch module, the switch can be designed for a variety of applications. The overlays may be rotated for vertical or horizontal placement. The trim plate conceals the transitions between the overlays and defines the final switch orientation.

Lastly, a cover bezel accepts the switch module with overlays and the trim plate and is secured together with screws. The cover bezel allows different style profiles to be accommodated. One of the inherent features of the CSS is its ability to be fit compatible with former CMS/IFE switch offerings. By defining a cover bezel that fits an existing cutout, ALTO may be able to provide a CMS/IFE upgrade solution without changing the woodwork.

The CSS also consists of controllers that provide load control and temperature control. The 8 Channel relay controller is a configurable unit that interfaces with the switches. This controller approach allows a user to easily configure a system to meet any requirement. A temperature controller allows for passenger control in the cabin.



If you are looking for new or fit compatible switch panels to replace your obsolete system or just looking for a lower cost CMS/IFE alternative, please give us a call. We'll be more than happy to assist you with your requirements.